

TV-511E

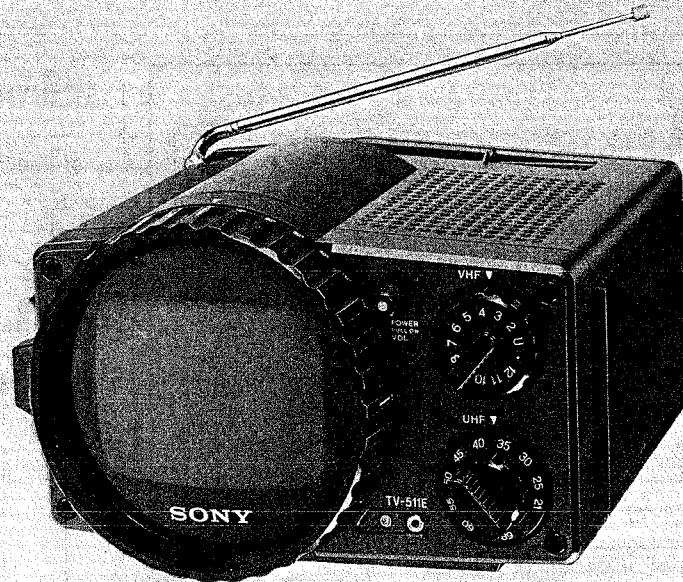

B & W TV

SPECIFICATIONS

Television System:	CCIR system (B, G and H)
Picture Tube:	12.2cm, 5" (screen measured diagonally), 55° deflection
Semiconductors:	28 transistors, 22 diodes and 1 IC
Antennas:	VHF/UHF: Built-in telescopic antenna 75Ω coaxial antenna socket
Channel Coverage:	VHF channels: E 2 – 12 UHF channels: E21 – 69
Intermediate Frequencies:	Picture i-f carrier: 38.9MHz Sound i-f carrier: 33.4MHz
Sound System:	5.5MHz intercarrier Output power: 300mW (max.) Speaker: 7.7cm (3 inches) dia, 32Ω
Automatic Controls:	AFC (automatic frequency control) AGC (automatic gain control)
Anode Voltage:	7.5kV at 60μA beam current
Hochspannung:	7.5kV bei 60μA Strahlstrom
Power Requirements:	220V ac, 50Hz, 13.5V dc, nine batteries size D (IEC Designation R20) 12 V car battery with optional sony car battery cord DCC-16E
Power Consumption:	20W ac (max.) 7W dc (average)
Dimensions:	Approx. 284(w) x 173(h) x 287(d) mm 11 ¹ / ₈ (w) x 6 ⁷ / ₈ (h) x 11 ¹ / ₄ (d) inches
Net Weight:	Approx. 3.5kg (7 lb 11 oz)
Accessories Supplied:	Earphone (ME-20H) AC power cord Battery holder Instruction manual

SAFETY-RELATED COMPONENT WARNING !!

COMPONENTS IDENTIFIED BY SHADING AND  MARK ON THE SCHEMATIC DIAGRAMS, EXPLODED VIEWS AND IN THE PARTS LIST ARE CRITICAL TO SAFE OPERATION. REPLACE THESE COMPONENTS WITH SONY PARTS WHOSE PART NUMBERS APPEAR AS SHOWN IN THIS MANUAL OR IN SUPPLEMENTS PUBLISHED BY SONY. CIRCUIT ADJUSTMENTS THAT ARE CRITICAL TO SAFE OPERATION ARE IDENTIFIED IN THIS MANUAL. FOLLOW THESE PROCEDURES WHENEVER CRITICAL COMPONENTS ARE REPLACED OR IMPROPER OPERATION IS SUSPECTED.

SICHERHEITSHINWEIS FÜR KOMPONENTEN !!

DIE IN DEN SCHALTBILDERN, DEN IN EINZELTEILE AUFGELOSTEN PERSPEKTIVISCHEN ZEICHNUNGEN UND DEN TEILELISTEN SCHRAFFIERT EINGEZEICHNETE UND DURCH DAS ZEICHEN  GEKENNZEICHNETE KOMPONENTEN SIND FÜR DIE BETRIEBSSICHERHEIT KRITISCH. DIESE KOMPONENTEN SIND DURCH SOLCHE SONY TEILE ZU ERSETZEN, DEREN TEILENUMMERN IN DIESEM HANDBUCH ODER IN VON SONY HERAUSGEGEBENEN ERGÄNZUNGEN ANGEGBEN SIND.

AUF FÜR DIE BETRIEBSSICHERHEIT KRITISCHE SCHALTUNGSEINSTELLUNGEN WIRD IN DIESEM HANDBUCH HINGEWIESEN.

BEFOLGEN SIE DIESE ANWEISUNGEN STETS, WENN KRITISCHE KOMPONENTEN AUSGEWECHSELT WERDEN ODER VERDACHT AUF FUNKTIONSSTÖRUNGEN BESTEHT.

SONY[®]

SERVICE MANUAL

SECTION 1
BLOCK DIAGRAM

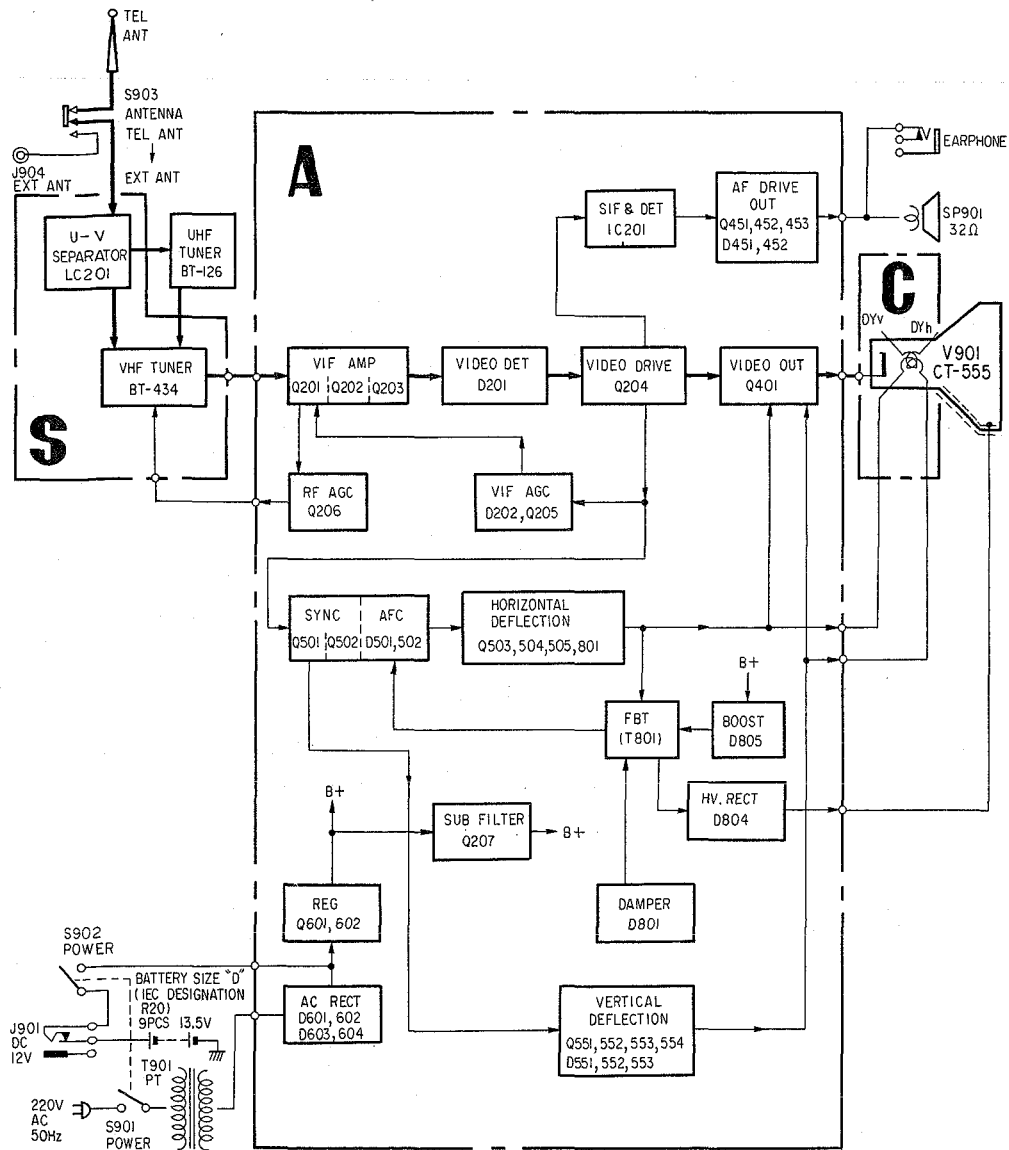

CIRCUIT BOARDS LOCATION

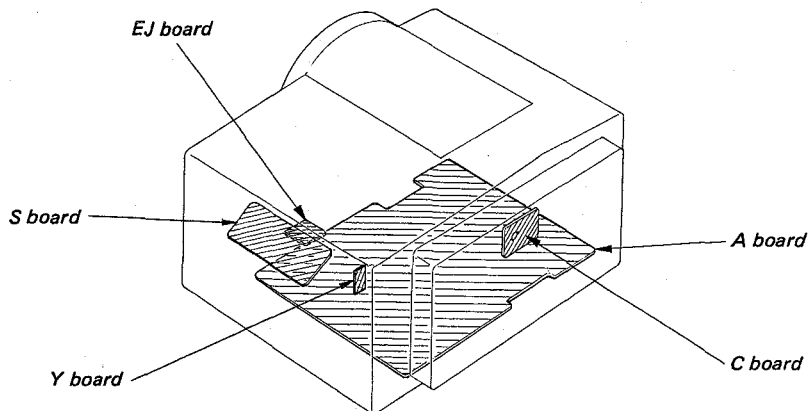

**SECTION 2
DISASSEMBLY**

- Note**
- Follow the disassembly procedure in the numerical order given.
 - When removing the rear cover, take out all the screws around marked ⇒ on it.
 - All screws are Phillips (cross recess) type unless otherwise noted. (—) = slotted head.

2-1. CABINET REMOVAL

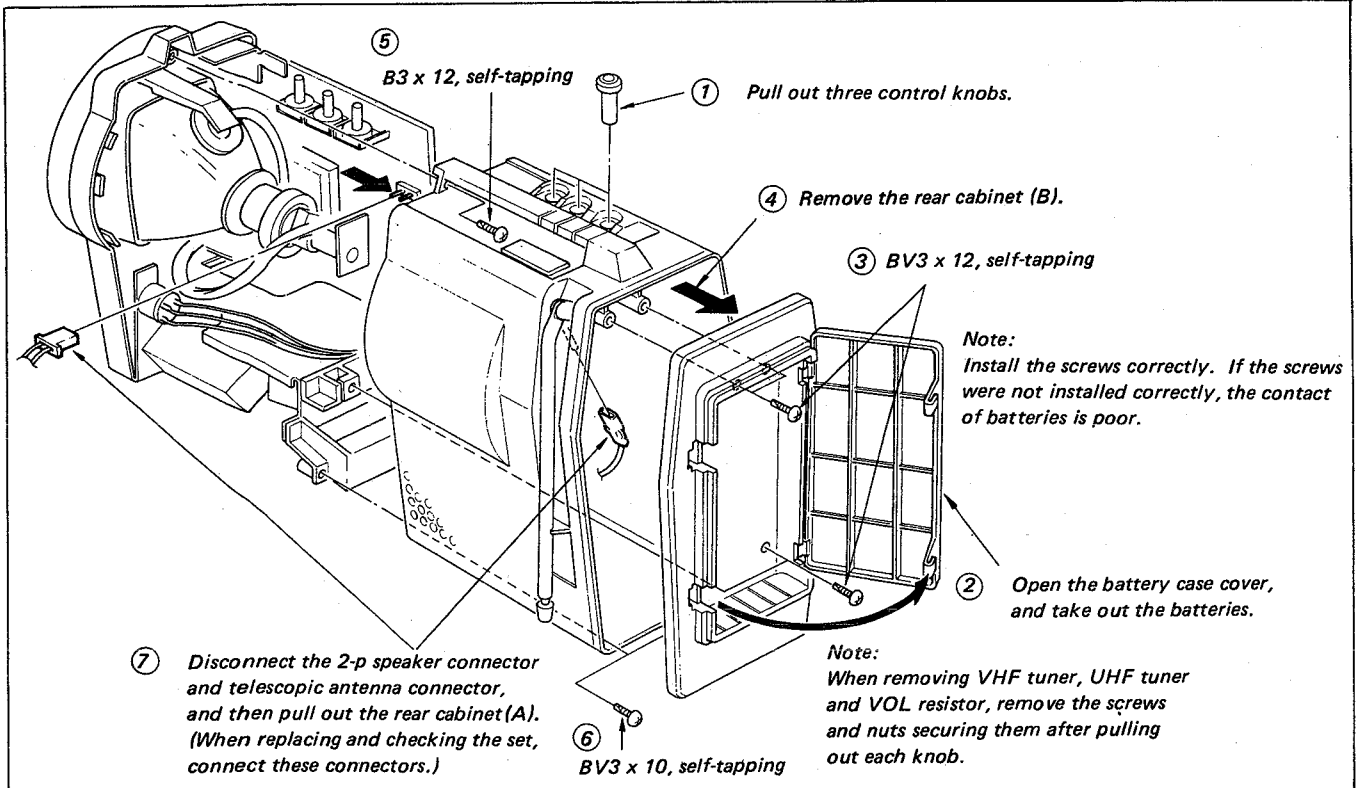

2-2. PICTURE TUBE REMOVAL

Proceed to the following steps after cabinet removal.

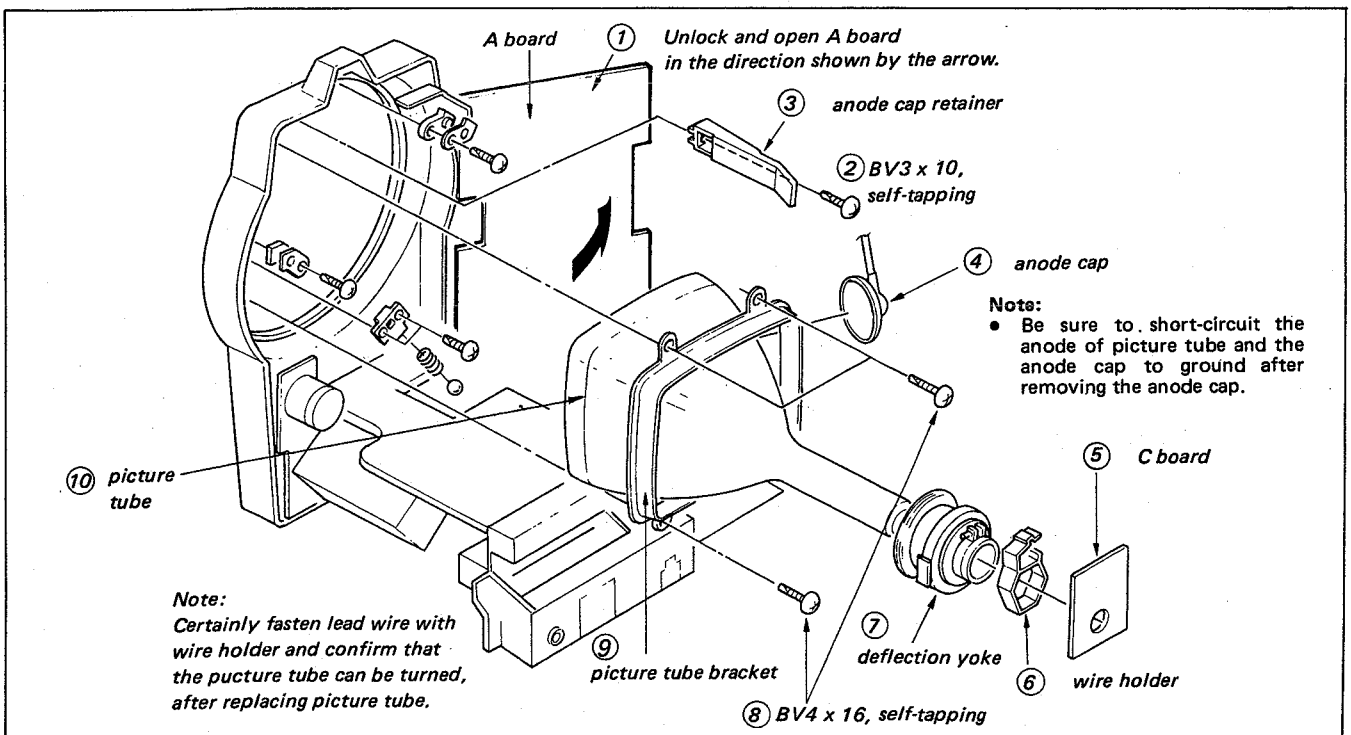

2-3. PROTECTOR REMOVAL

Remove picture tube from the front cabinet and then proceed to the following steps.

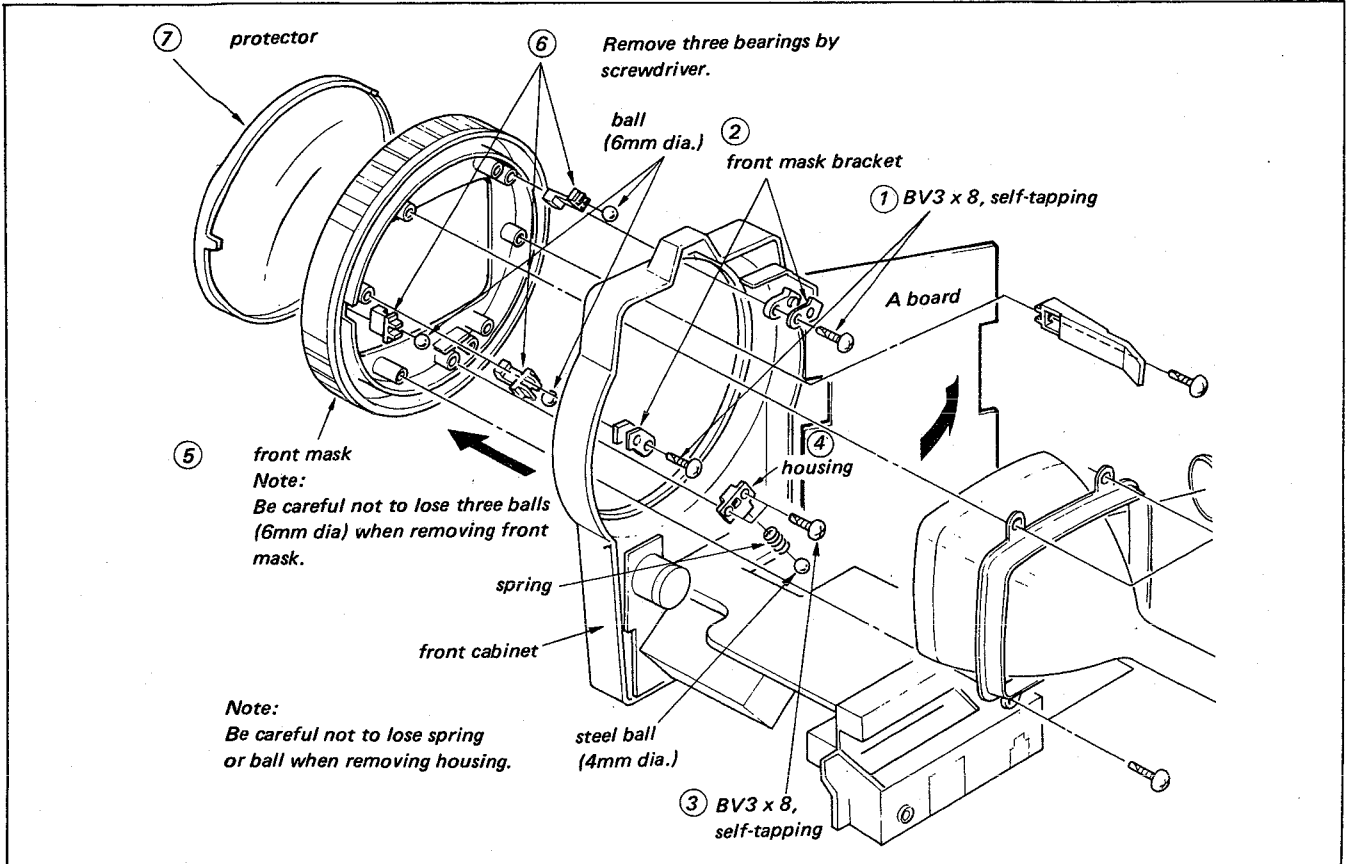

**SECTION 3
CIRCUIT ADJUSTMENTS**

3-1. A BOARD ADJUSTMENTS (1)

Note:

- The Equipment Required VOM
- These adjustment should be performed with rated power supply voltage, unless otherwise noted.

- Preparations:
1. Tune in an off-air signal.
 2. Set V. HOLD control for correct sync.
 3. BRIGHT control) MAX. (fully clockwise)
CONTR control

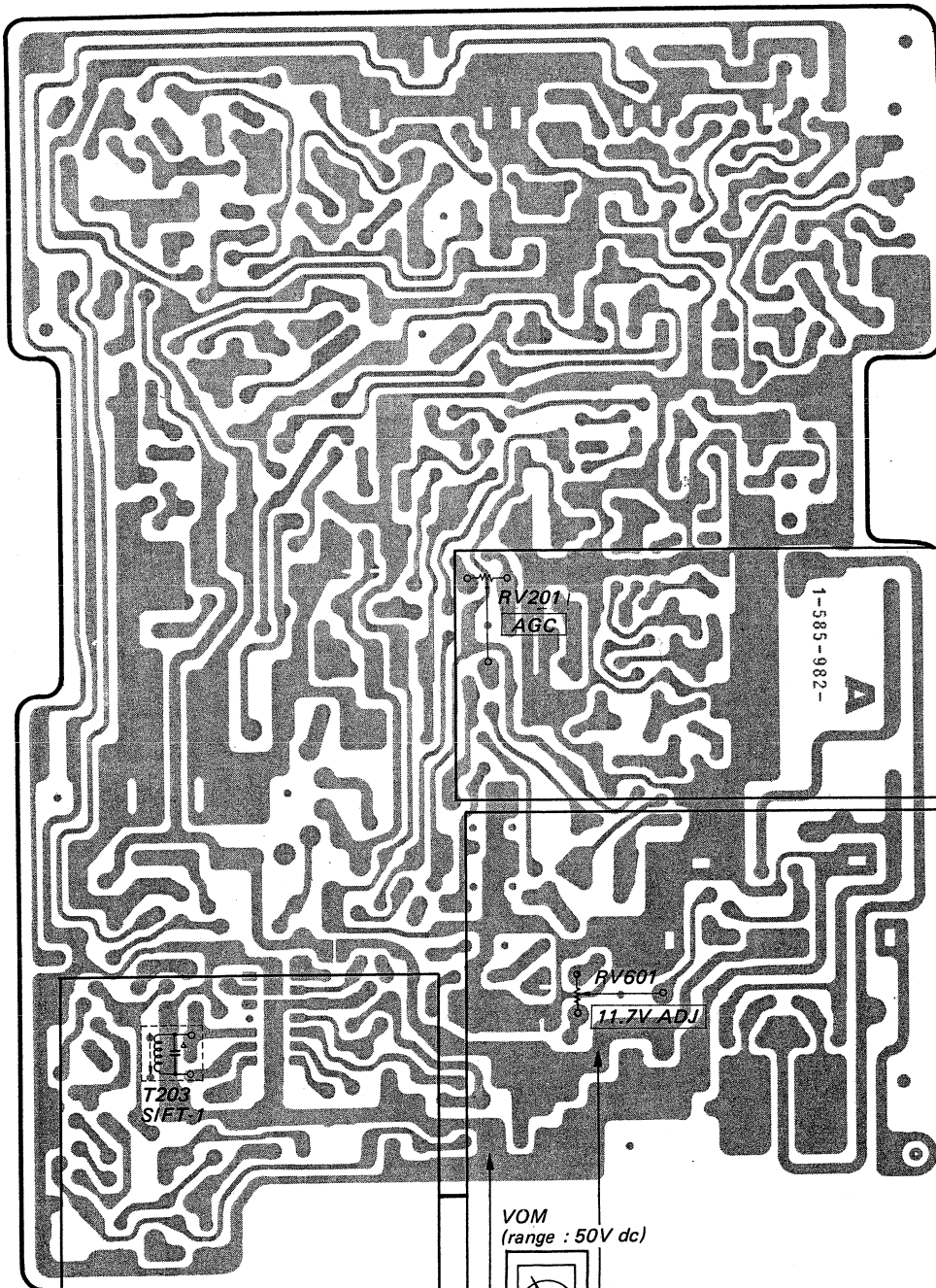

AGC

1. Tune in a weak off-air signal to obtain snow noise on the picture.
2. Set RV201 to the position where snow noise just disappears.
3. Readjust RV201 if snow noise or unstable picture persists in other channel.

11.7V ADJ

1. Preparations:

- 1-1. Tune in an off-air signal.
- 1-2. Set V.HOLD control for correct sync.
- 1-3. BRIGHT control.....MAX. (fully clockwise)
CONTR control.....MIN. (fully counterclockwise)

2. Confirm that the ac power voltage is 220V
3. Adjust RV601 for 11.7V±0.1V dc.

SIF

1. Adjust T203 for the maximum clear sound.
2. Confirm that no buzz sound is heard.

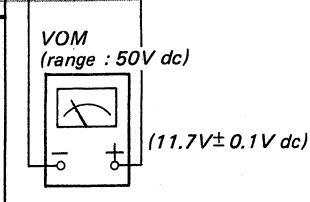

3-2. A BOARD ADJUSTMENTS (2)

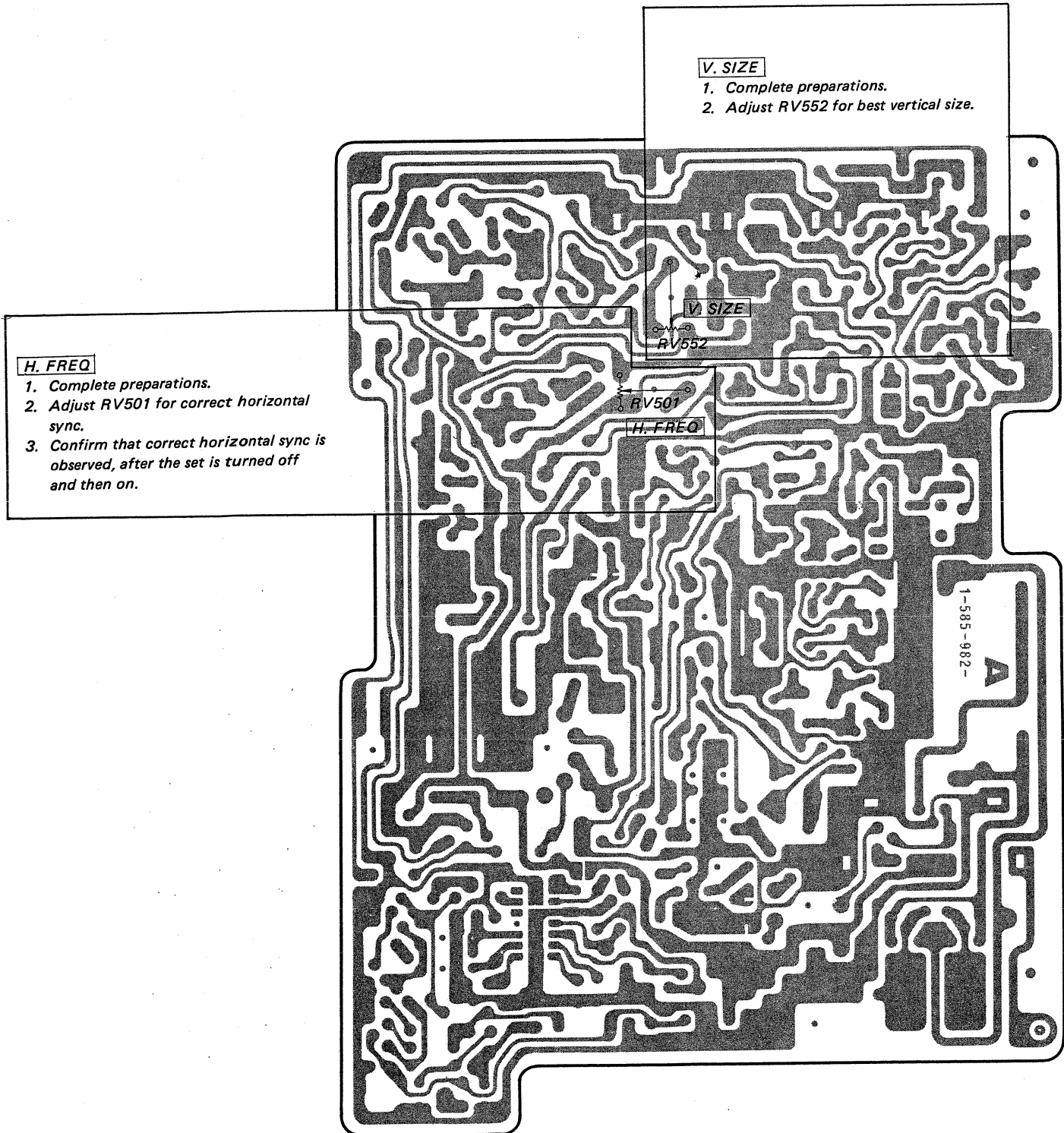

SECTION 4
DIAGRAMS

1/4 WATT CARBON RESISTORS (A)

1.0	1-244-601-11	10	1-244-625-11	100	1-244-649-11	1.0k	1-244-673-11	10k	1-244-697-11	100k	1-244-721-11	1.0M	1-244-745-11
1.1	1-244-602-11	11	1-244-626-11	110	1-244-650-11	1.1k	1-244-674-11	11k	1-244-698-11	110k	1-244-722-11	1.1M	1-244-746-11
1.2	1-244-603-11	12	1-244-627-11	120	1-244-651-11	1.2k	1-244-675-11	12k	1-244-699-11	120k	1-244-723-11	1.2M	1-244-747-11
1.3	1-244-604-11	13	1-244-628-11	130	1-244-652-11	1.3k	1-244-676-11	13k	1-244-700-11	130k	1-244-724-11	1.3M	1-244-748-11
1.5	1-244-605-11	15	1-244-629-11	150	1-244-653-11	1.5k	1-244-677-11	15k	1-244-701-11	150k	1-244-725-11	1.5M	1-244-749-11
1.6	1-244-606-11	16	1-244-630-11	160	1-244-654-11	1.6k	1-244-678-11	16k	1-244-702-11	160k	1-244-726-11	1.6M	1-244-750-11
1.8	1-244-607-11	18	1-244-631-11	180	1-244-655-11	1.8k	1-244-679-11	18k	1-244-703-11	180k	1-244-727-11	1.8M	1-244-751-11
2.0	1-244-608-11	20	1-244-632-11	200	1-244-656-11	2.0k	1-244-680-11	20k	1-244-704-11	200k	1-244-728-11	2.0M	1-244-752-11
2.2	1-244-609-11	22	1-244-633-11	220	1-244-657-11	2.2k	1-244-681-11	22k	1-244-705-11	220k	1-244-729-11	2.2M	1-244-753-11
2.4	1-244-610-11	24	1-244-634-11	240	1-244-658-11	2.4k	1-244-682-11	24k	1-244-706-11	240k	1-244-730-11	2.4M	1-244-754-11
2.7	1-244-611-11	27	1-244-635-11	270	1-244-659-11	2.7k	1-244-683-11	27k	1-244-707-11	270k	1-244-731-11	2.7M	1-244-755-11
3.0	1-244-612-11	30	1-244-636-11	300	1-244-660-11	3.0k	1-244-684-11	30k	1-244-708-11	300k	1-244-732-11	3.0M	1-244-756-11
3.3	1-244-613-11	33	1-244-637-11	330	1-244-661-11	3.3k	1-244-685-11	33k	1-244-709-11	330k	1-244-733-11	3.3M	1-244-757-11
3.6	1-244-614-11	36	1-244-638-11	360	1-244-662-11	3.6k	1-244-686-11	36k	1-244-710-11	360k	1-244-734-11	3.6M	1-244-758-11
3.9	1-244-615-11	39	1-244-639-11	390	1-244-663-11	3.9k	1-244-687-11	39k	1-244-711-11	390k	1-244-735-11	3.9M	1-244-759-11
4.3	1-244-616-11	43	1-244-640-11	430	1-244-664-11	4.3k	1-244-688-11	43k	1-244-712-11	430k	1-244-736-11	4.3M	1-244-760-11
4.7	1-244-617-11	47	1-244-641-11	470	1-244-665-11	4.7k	1-244-689-11	47k	1-244-713-11	470k	1-244-737-11	4.7M	1-244-761-11
5.1	1-244-618-11	51	1-244-642-11	510	1-244-666-11	5.1k	1-244-690-11	51k	1-244-714-11	510k	1-244-738-11	5.1M	1-244-762-11
5.6	1-244-619-11	56	1-244-643-11	560	1-244-667-11	5.6k	1-244-691-11	56k	1-244-715-11	560k	1-244-739-11		
6.2	1-244-620-11	62	1-244-644-11	620	1-244-668-11	6.2k	1-244-692-11	62k	1-244-716-11	620k	1-244-740-11		
6.8	1-244-621-11	68	1-244-645-11	680	1-244-669-11	6.8k	1-244-693-11	68k	1-244-717-11	680k	1-244-741-11		
7.5	1-244-622-11	75	1-244-646-11	750	1-244-670-11	7.5k	1-244-694-11	75k	1-244-718-11	750k	1-244-742-11		
8.2	1-244-623-11	82	1-244-647-11	820	1-244-671-11	8.2k	1-244-695-11	82k	1-244-719-11	820k	1-244-743-11		
9.1	1-244-624-11	91	1-244-648-11	910	1-244-672-11	9.1k	1-244-696-11	91k	1-244-720-11	910k	1-244-744-11		

HARDWARE NOMENCLATURE

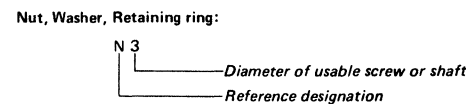
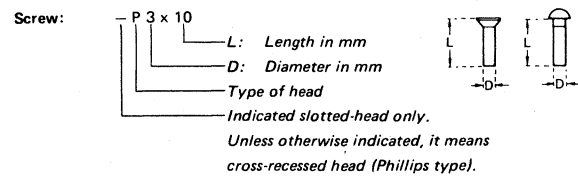

Reference Designation	Shape	Description	Remarks
SCREWS			
P		pan-head screw	binding-head (B) screw for replacement
PWH		pan-head screw with washer face	binding-head (B) screw and flat washer for replacement
PS PSP		pan-head screw with spring washer	binding-head (B) screw and spring washer for replacement
PSW PSPW		pan-head screw with spring and flat washers	binding-head (B) screw and spring and flat washers for replacement
R		round-head screw	binding-head (B) screw for replacement
K		flat-countersunk-head screw	
RK		oval-countersunk-head screw	
B		binding-head screw	
T		truss-head screw	binding-head (B) screw for replacement
F		flat-fillister-head screw	
RF		fillister-head screw	
BV		braizer-head screw	

Reference Designation	Shape	Description	Remarks
SELF-TAPPING SCREWS			
TA		self-tapping screw	ex: TA, P 3 x 10
PTP		pan-head self-tapping screw	binding-head self-tapping (TA, B) screw for replacement
PTPWH		pan-head self-tapping screw with washer face	binding-head self-tapping (TA, B) screw and flat washer for replacement
PTTWH		pan-head thread-rolling screw with washer face	binding-head (B) screw and flat washer for replacement
SET SCREWS			
SC		set screw	
SC		hexagon-socket set screw	ex: SC 2.6 x 4, hexagon socket
NUT			
N		nut	
WASHERS			
W		flat washer	
SW		spring washer	
LW		internal-tooth lock washer	ex: LW3, internal
LW		external-tooth lock washer	ex: LW3, external
RETAINING RINGS			
E		retaining ring	
G		grip-type retaining ring	

DC RESISTANCE AND WINDING DIAGRAMS OF COILS AND TRANSFORMERS

L901 (DY)

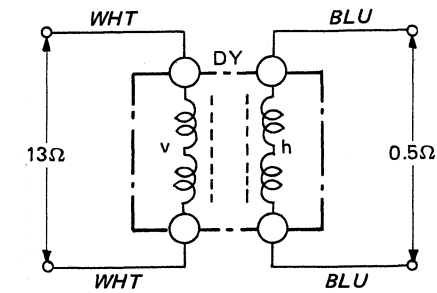
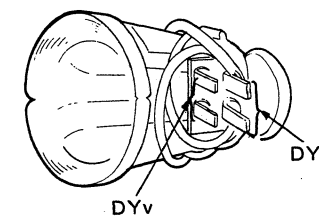

T501 (HDT)

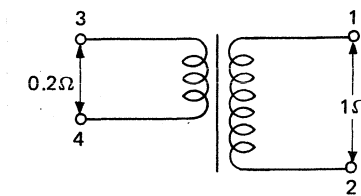
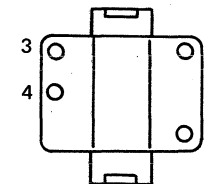

T801 (FBT)

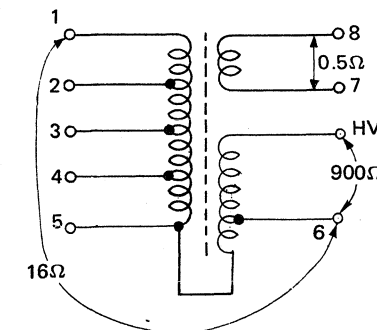
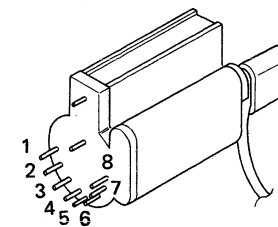

T901 (PT)

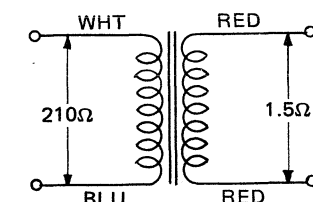
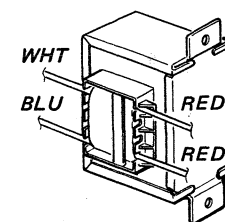

Note: DC resistance measurements shown with coils disconnected from circuit.

SECTION 4
DIAGRAMS

DC RESISTANCE AND WINDING DIAGRAMS OF COILS AND TRANSFORMERS

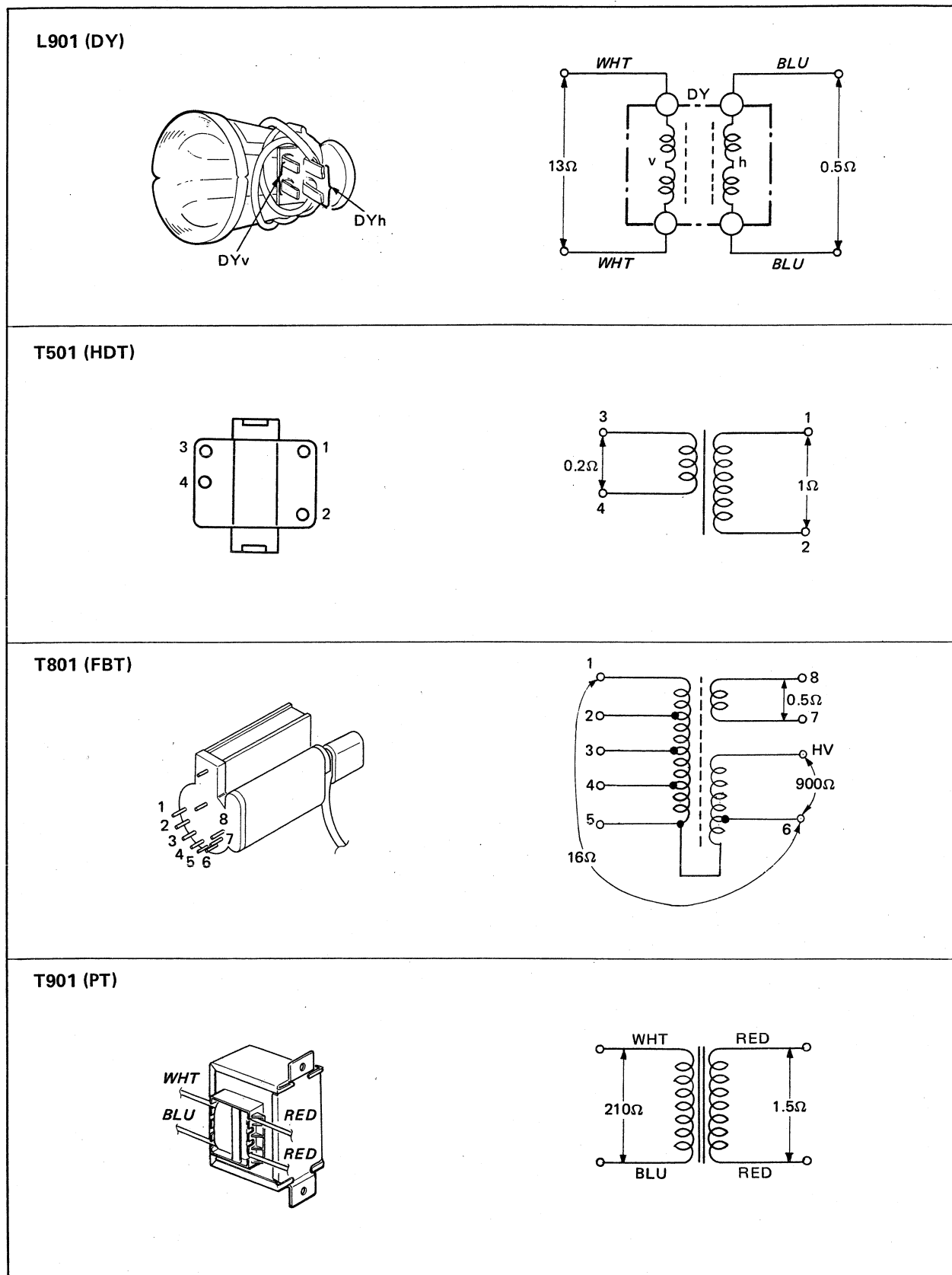

Note: DC resistance measurements shown with coils disconnected from circuit.

4.2. UHF AND VHF TUNER SCHEMATIC DIAGRAMS

- UHF tuner (BT-126) -

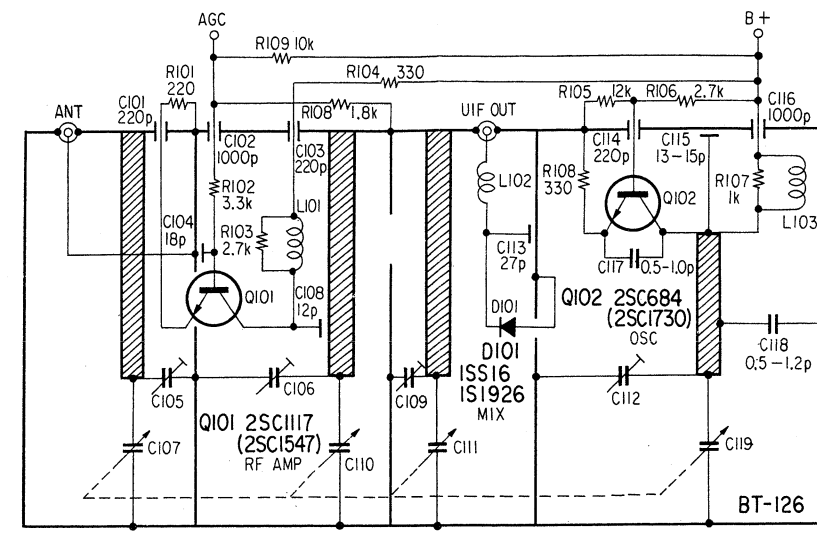

- VHF tuner (BT-434) -

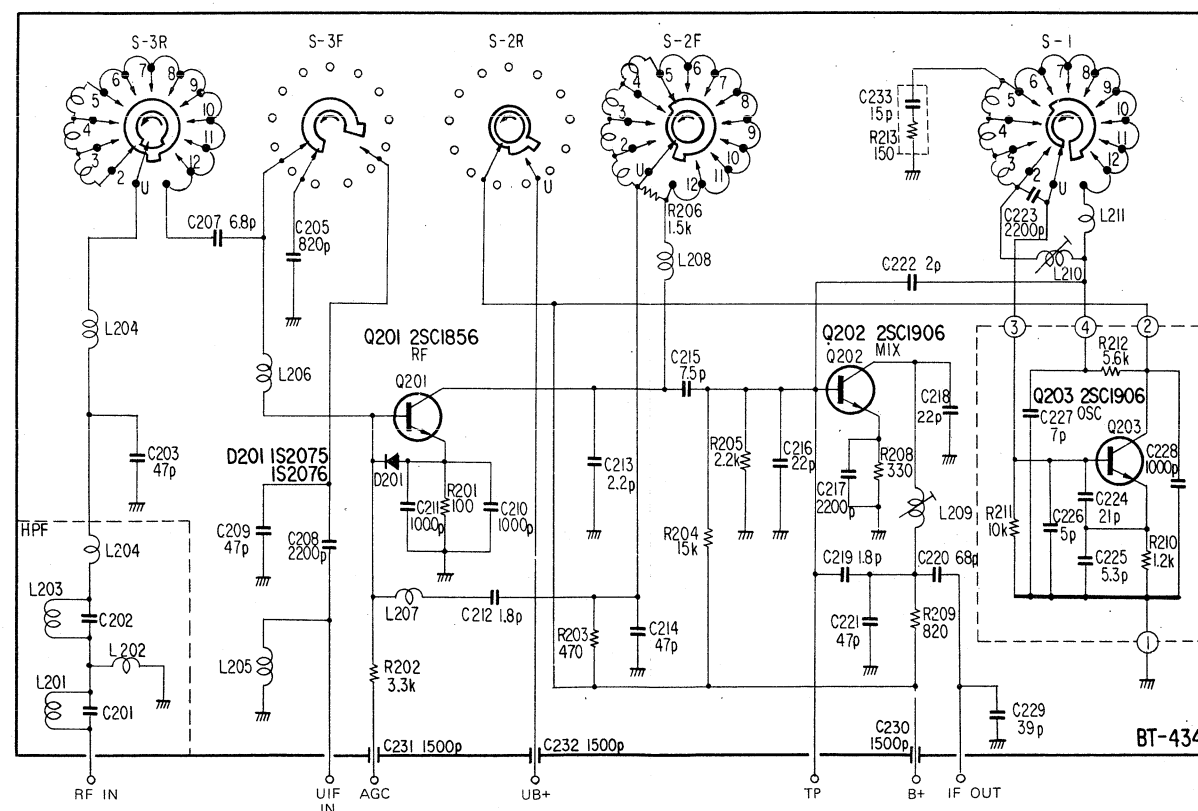

Note: Tuner reference numbers are not included in the Electrical Parts List (Page 17 - 19).

4.3. MOUNTING DIAGRAMS

- Conductor Side -

- A, C, EJ, S and Y Boards -

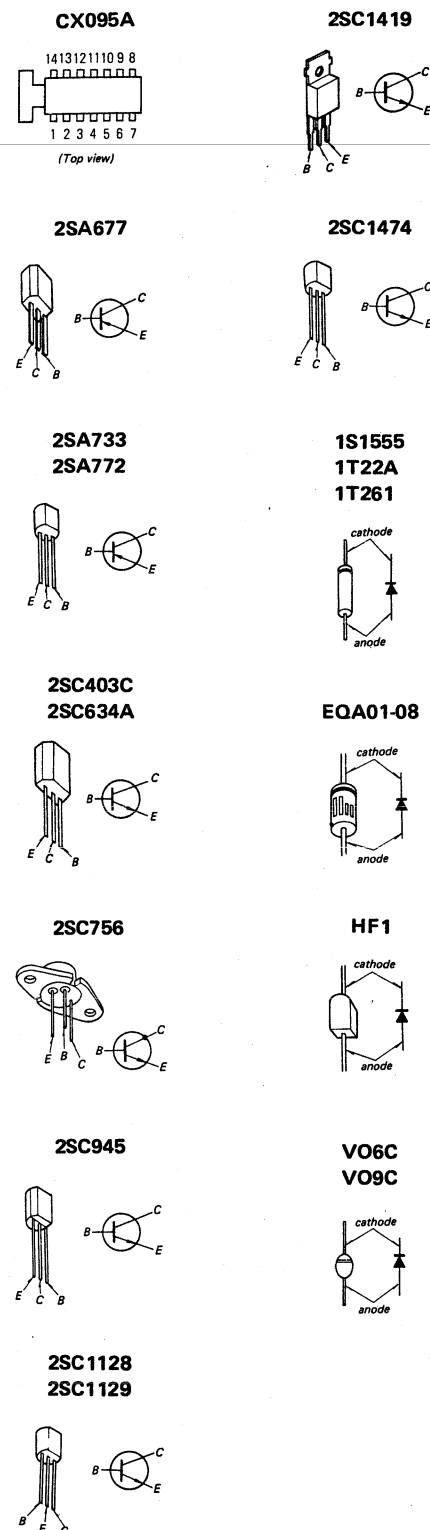

Note:
 ● — : parts extracted from the component side.
 ● — : parts extracted from the conductor side.
 ● ■ : part mounted on the conductor side.

Q	D	ADJ
401	551 553 552	
552		
554		
553		
501		RV552
502	501	
503		RV501
504		
205	502	
204	503	
801		
505	202	
201		RV201
203		
802		
206		
202		
804		
801		
201		
601		
207	803	
602		
805		
603		
451		RV601
IC201		
452	452	
451	451	T203
453	604	
	602	
	601	
	603	
452		

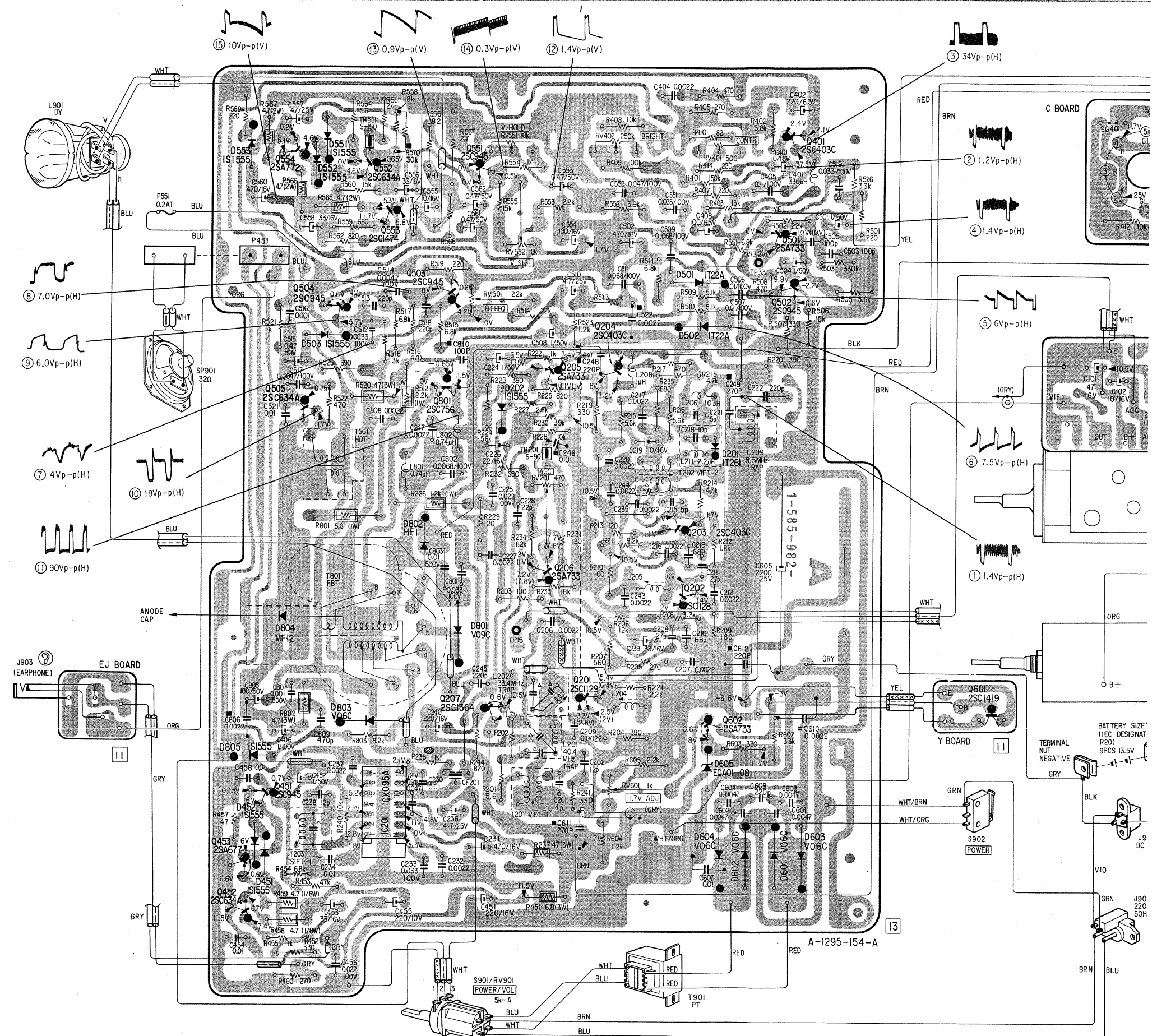

TV-511E TV-511E

Note: The components identified by shading and Δ mark are critical for safety. Replace only with part number specified.

4-4. SCHEMATIC DIAGRAM

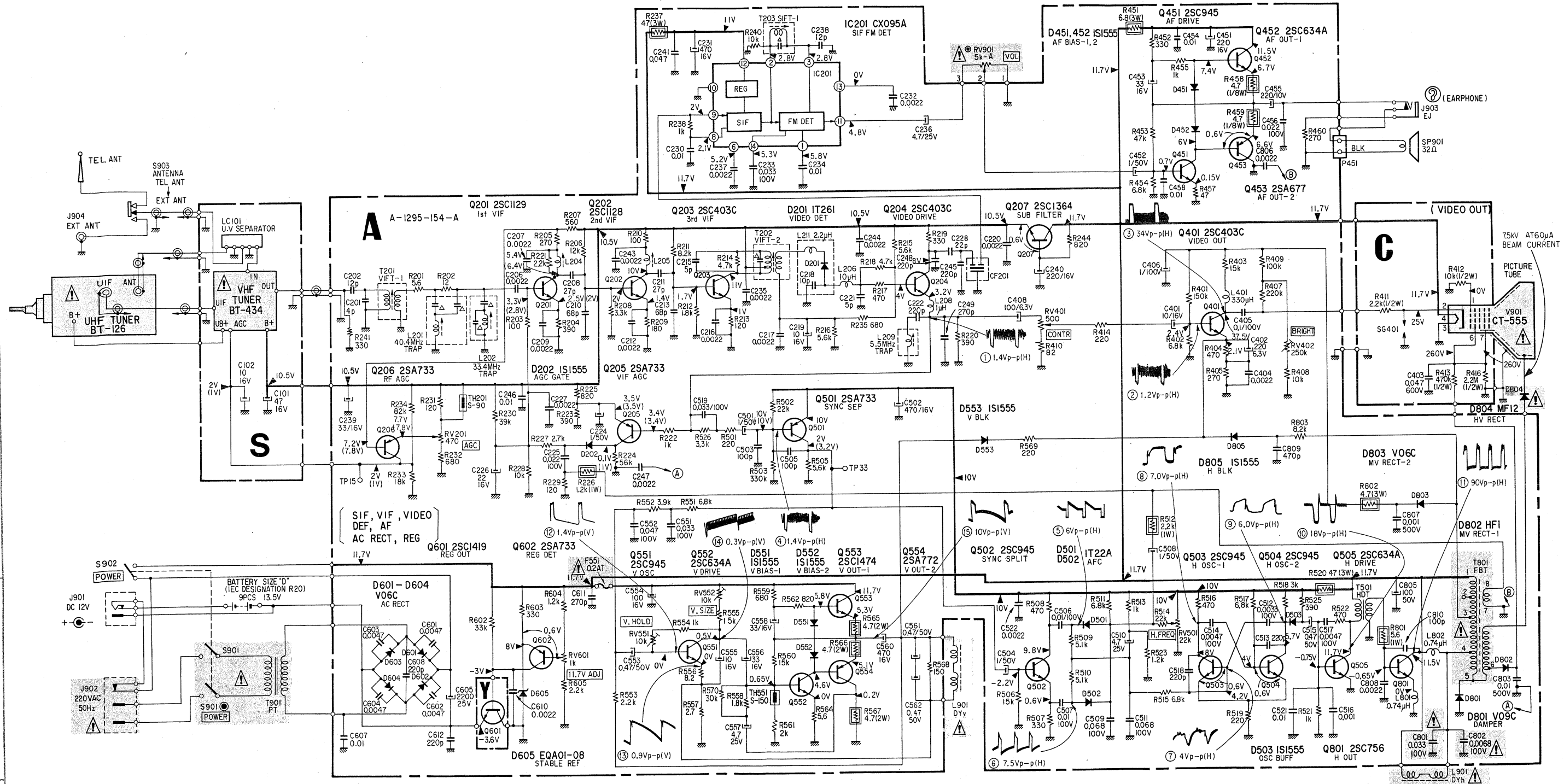

Note:

- All capacitors are in μF unless otherwise noted. P: μM F 50WV or less are not indicated except for electrolytics.
- All resistors are in ohms, $\frac{1}{4}$ W unless otherwise noted. k: 1000 Ω , M: 1000k Ω .
- Δ : internal component.

- \square : nonflammable resistor.
- \square : panel designation.
- All variable and adjustable resistors have characteristic curve B, unless otherwise noted.
- \odot : S901 is ganged to RV901.

- Voltages are dc with respect to ground unless otherwise noted.
- Voltage variations may be noted due to normal production tolerances.
- --- : B+ bus.

- Voltages are taken under tuned conditions with VOM (20 k Ω /V).
- () : detuned
- (BRIGHT control MAX)
- (CONTR control MIN)

TV-511E TV-511E

SECTION 5 EXPLODED VIEW

A B C D E F G H

Note: The components identified by shading and  mark are critical for safety. Replace only with part number specified.

Note:

- Items with no part number and/or no description are not stocked because they are seldom required for routine service.
- All screws are Phillips (cross recess) type unless otherwise noted. (—) = slotted head
- : BV3x8, self-tapping
- : BV3x10, self-tapping

1

2

3

4

5

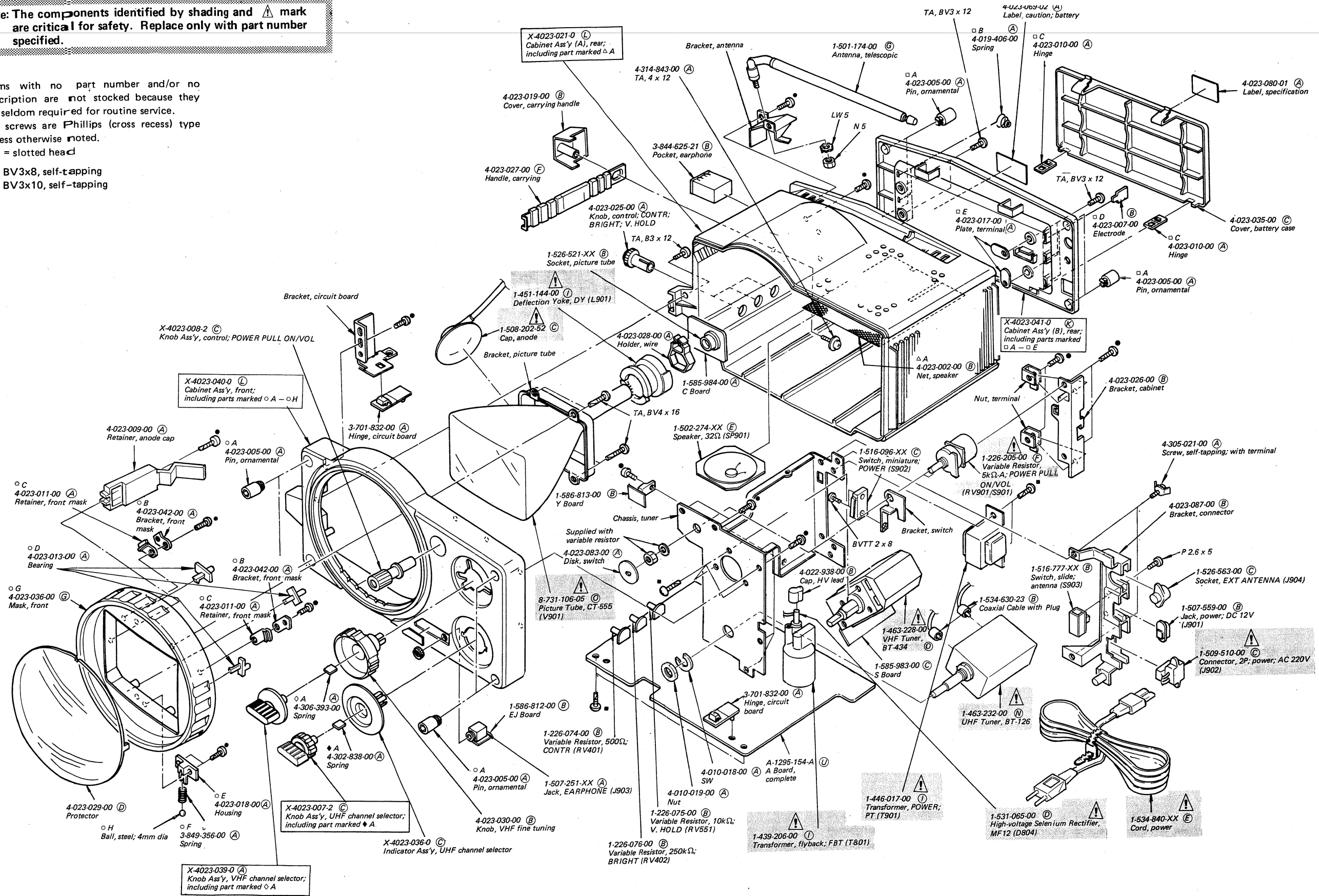

SECTION 6
ELECTRICAL PARTS LIST

Ref. No. Part No. Description

TUNERS AND CIRCUIT BOARDS

⚠ 1-463-228-00 Ⓞ VHF Tuner, BT-434
⚠ 1-463-232-00 Ⓝ UHF Tuner, BT-126

1-585-893-00 Ⓞ S Board
1-585-984-00 ⓐ C Board
1-586-812-00 ⓑ EJ Board
1-586-813-00 ⓑ Y Board
A-1 295-154-A Ⓚ A Board, complete

SEMICONDUCTORS

Transistors

Q201 ⓑ 2SC1129
Q202 ⓑ 2SC1128
Q203, 204 ⓑ 2SC403C
Q205, 206 ⓑ 2SA733
Q207 ⓑ 2SC1364

Q401 ⓑ 2SC403C
Q451 ⓑ 2SC945
Q452 ⓑ 2SC634A
Q453 ⓑ 2SA677
Q501 ⓑ 2SA733

Q502-504 ⓑ 2SC945
Q505 ⓑ 2SC634A
Q551 ⓑ 2SC945
Q552 ⓑ 2SC634A
Q553 ⓑ 2SC1474

Q554 Ⓞ 2SA772
Q601 Ⓞ 2SC1419
Q602 ⓑ 2SA733
Q801 Ⓚ 2SC756

Diodes

D201 ⓐ 1T261
D202 ⓑ 1S1555
D451, 452 ⓑ 1S1555
D501, 502 ⓐ 1T22A
D503 ⓑ 1S1555

Ref. No. Part No. Description

D551-553 ⓑ 1S1555
D601-604 ⓐ V06C
D605 ⓑ EQA01-08
D801 ⓐ V09C
D802 ⓑ HF1

D803 ⓐ V06C
D805 ⓑ 1S1555

IC

IC201 ⓕ CX095A

Miscellaneous

TH201 1-800-194-00 ⓐ Thermistor, S-90
TH551 1-800-378-00 ⓐ Thermistor, S-150

COILS

All coils are microinductors unless otherwise noted.

L201 1-409-298-00 ⓑ 40.4 MHz Trap
L202 1-409-299-00 ⓑ 33.4 MHz Trap
L204, 205 1-459-178-00 ⓑ VIF
L206 1-407-157-XX ⓐ 10μH
L208 1-407-178-XX ⓐ 1μH

L209 1-409-179-00 ⓐ 5.5MHz Trap
L211 1-407-182-XX ⓐ 2.2μH
L401 1-407-175-XX ⓐ 330μH
L801, 802 1-407-365-00 ⓐ 0.74μH, spook choke
L901 ⚠ 1-451-144-00 Ⓚ Deflection Yoke, DY

LC101 1-417-060-00 ⓑ UV Separator

TRANSFORMERS AND FILTER

CF201 1-527-263-00 ⓑ Ceramic Filter

T201 1-403-519-00 ⓑ VIFT-1
T202 1-403-730-00 ⓑ VIFT-2
T203 1-403-842-00 ⓑ SIFT-1
T501 1-437-021-00 ⓑ Horizontal Drive, HDT
T801 ⚠ 1-439-206-00 Ⓚ Flyback, FBT
T901 ⚠ 1-446-017-00 Ⓚ Power, PT

Ref. No. Part No. Description

CAPACITORS

All capacitors are in μF and ceramic unless otherwise noted.
50WV or less are not indicated except for electrolytics.
p : μμF, elect : electrolytic

C101 1-121-409-11 ⓐ 47 16V elect
C102 1-121-651-11 ⓐ 10 16V elect
C201 1-102-937-11 ⓐ 4p
C202 1-102-949-11 ⓐ 12p
C206, 207 1-102-121-11 ⓐ 0.0022

C208 1-102-961-11 ⓐ 27p
C209 1-102-121-11 ⓐ 0.0022
C210 1-101-888-11 ⓐ 68p
C211 1-102-961-11 ⓐ 27p
C212 1-102-121-11 ⓐ 0.0022

C213 1-101-888-11 ⓐ 68p
C215 1-102-942-11 ⓐ 5p
C216, 217 1-102-121-11 ⓐ 0.0022
C218 1-102-947-11 ⓐ 10p
C219 1-121-651-11 ⓐ 10 16V elect

C220 1-102-121-11 ⓐ 0.0022
C221 1-102-942-11 ⓐ 5p
C222 1-102-110-11 ⓐ 220p
C224 1-121-391-11 ⓐ 1 50V elect
C225 1-108-381-12 ⓑ 0.022 100V mylar

C226 1-121-479-11 ⓐ 22 16V elect
C227 1-102-121-11 ⓐ 0.0022
C228 1-102-959-11 ⓐ 22p
C230 1-101-118-11 ⓐ 0.01
C231 1-121-940-11 ⓑ 470 16V elect

C232 1-102-121-11 ⓐ 0.0022
C233 1-108-383-12 ⓐ 0.033 100V mylar
C234 1-101-004-11 ⓐ 0.01
C235 1-102-121-11 ⓐ 0.0022
C236 1-121-395-11 ⓐ 4.7 25V elect

C237 1-102-121-11 ⓐ 0.0022
C238 1-102-637-11 ⓐ 12p
C239 1-121-404-11 ⓐ 33 16V elect
C240 1-123-068-11 ⓑ 220 16V elect
C241 1-101-006-11 ⓐ 0.047

Ref. No. Part No. Description

C243, 244 1-102-121-11 ⓐ 0.0022
C245 1-102-977-11 ⓐ 220p
C246 1-101-004-11 ⓐ 0.01
C247 1-102-121-11 ⓐ 0.0022
C248 1-102-983-11 Ⓞ 220p
C249 1-102-984-11 ⓐ 270p

C401 1-121-651-11 ⓐ 10 16V elect
C402 1-121-419-11 ⓐ 220 6.3V elect
C403 1-130-104-11 ⓑ 0.047 600V polyethylene
C404 1-102-121-11 ⓐ 0.0022
C405 1-108-389-12 ⓑ 0.1 100V mylar

C406 1-123-249-11 ⓐ 1 100V elect
C408 1-121-414-11 ⓐ 100 6.3V elect
C451 1-123-068-11 ⓑ 220 16V elect
C452 1-121-391-11 ⓐ 1 50V elect
C453 1-121-404-11 ⓐ 33 16V elect

C454 1-101-004-11 ⓐ 0.01
C455 1-123-072-11 ⓐ 220 10V elect
C456 1-108-381-12 ⓑ 0.022 100V mylar
C458 1-101-004-11 ⓐ 0.01
C501 1-121-391-11 ⓐ 1 50V elect

C502 1-121-940-11 ⓑ 470 16V elect
C503 1-102-973-11 ⓐ 100p
C504 1-121-391-11 ⓐ 1 50V elect
C505 1-102-973-11 ⓐ 100p
C506, 507 1-108-377-12 ⓐ 0.01 100V mylar

C508 1-121-391-11 ⓐ 1 50V elect
C509 1-108-387-12 ⓐ 0.068 100V mylar
C510 1-121-395-11 ⓐ 4.7 25V elect
C511 1-108-387-12 ⓐ 0.068 100V mylar
C512 1-108-371-12 ⓐ 0.0033 100V mylar

C513 1-102-977-11 ⓐ 220p
C514 1-108-373-12 ⓐ 0.0047 100V mylar
C515 1-121-726-11 ⓐ 0.47 50V elect
C516 1-101-001-11 ⓐ 0.001
C517 1-108-373-12 ⓐ 0.0047 100V mylar

C518 1-102-977-11 ⓐ 220p
C519 1-108-383-12 ⓐ 0.033 100V mylar
C521 1-101-004-11 ⓐ 0.01
C522 1-102-121-11 ⓐ 0.0022
C551 1-108-632-11 ⓐ 0.033 100V mylar

Note: The components identified by shading and ⚠ mark are critical for safety. Replace only with part number specified.

TV-511E TV-511E

Ref. No.	Part No.	Description
C552	1-108-385-12	(A) 0.047 100V mylar
C553	1-121-726-11	(A) 0.47 50V elect
C554	1-121-415-11	(A) 100 16V elect
C555	1-131-158-11	(B) 10 16V tantalum
C556	1-121-404-11	(A) 33 16V elect
C557	1-121-395-11	(A) 4.7 25V elect
C558	1-121-403-11	(A) 33 16V elect
C560	1-121-940-11	(B) 470 16V elect
C561, 562	1-121-726-11	(A) 0.47 50V elect
C601-604	1-101-003-11	(A) 0.0047
C605	1-119-448-11	(C) 2200 25V elect
C607	1-101-004-11	(A) 0.01
C608	1-102-977-11	(A) 220p
C610	1-102-121-11	(A) 0.0022
C611	1-102-984-11	(A) 270p
C612	1-102-977-11	(A) 220p
C801	(A) 1-108-383-12	(A) 0.033 100V mylar
C802	(A) 1-108-375-12	(A) 0.0068 100V mylar
C803	1-102-050-11	(A) 0.01 500V
C805	1-123-059-11	(B) 100 50V elect
C806	1-102-121-11	(A) 0.0022
C807	1-102-038-11	(A) 0.001 500V
C808	1-102-121-11	(A) 0.0022
C809	1-102-823-11	(A) 470p
C810	1-102-973-11	(A) 100p

RESISTORS

All resistors are in ohms. Common 1/4W carbon resistors are omitted. Refer to the list on page 7 for their part numbers. All adjustable and variable resistors have characteristic curve B, unless otherwise noted. k : 1000Ω, M : 1000kΩ

R226	1-213-144-11	(A) 1.2k	1W	metal oxide (nonflammable)
R237	1-206-527-11	(B) 47	3W	metal oxide (nonflammable)
R411	1-202-581-31	(A) 2.2k	1/2W	composition
R412	1-202-597-31	(A) 10k	1/2W	composition
R413	1-202-637-31	(B) 470k	1/2W	composition
R416	1-202-723-11	(A) 2.2M	1/2W	composition
R451	1-207-655-11	(B) 6.8	3W	metal oxide (nonflammable)
R458, 459	1-211-401-11	(A) 4.7	1/8W	carbon (nonflammable)

Ref. No.	Part No.	Description
R512	1-213-147-11	(B) 2.2k 1W metal oxide (nonflammable)
R520	1-206-527-11	(B) 47 3W metal oxide (nonflammable)
R565-567	1-207-624-11	(B) 4.7 2W metal oxide (nonflammable)
R801	1-212-369-11	(B) 5.6 1W metal oxide (nonflammable)
R802	1-207-653-11	(B) 4.7 3W metal oxide (nonflammable)
RV201	1-224-641-XX	(B) 470, adjustable; AGC
RV401	1-226-074-00	(B) 500, variable; CONTR
RV402	1-226-076-00	(B) 250k, variable; BRIGHT
RV501	1-224-646-XX	(B) 22k, adjustable; H. FREQ
RV551	1-226-075-00	(B) 10k, variable; V. HOLD
RV552	1-224-645-XX	(B) 10k, adjustable; V. SIZE
RV601	1-224-642-XX	(B) 1k, adjustable; 11.7V ADJ
RV901 } S901 }	(A) 1-226-205-00	(F) 5k-A, variable; POWER PULL ON/VOL

MISCELLANEOUS

D804	(A) 1-531-065-00	(D) High-voltage Selenium Rectifier, MF12
F551	(A) 1-532-387-00	(B) Fuse, 0.2AT
J901	1-507-559-00	(B) Jack, power; DC 12V
J902	(A) 1-509-510-00	(C) Connector, 2-p; power; AC 220V
J903	1-507-251-XX	(A) Jack, EARPHONE
J904	1-526-563-00	(C) Socket, EXT ANTENNA
S901	(A) - - - - -	included in RV901
S902	1-516-096-XX	(C) Switch, miniature; POWER
S903	1-516-777-XX	(B) Switch, slide; antenna
SG401	1-519-063-XX	(A) Spark Gap
SP901	1-502-274-XX	(E) Speaker, 32Ω
V901	(A) 8-731-106-05	(O) Picture Tube, CT-555
	1-501-174-00	(G) Antenna, telescopic
	(A) 1-508-202-52	(C) Cap, anode
	1-526-521-XX	(B) Socket, picture tube
	1-534-630-23	(B) Coaxial Cable with Plug
	1-534-784-12	(B) Coaxial Cable with Plug

PACKING MATERIALS AND ACCESSORIES

Part No.	Description
1-504-059-11	(C) Earphone, ME-20H
(A) 1-534-840-XX	(E) Cord, power
3-701-360-02	(A) Label, tack
3-701-625-00	(A) Bag, polyethylene
4-022-645-00	(B) Bag, protection
4-023-067-00	(C) Cushion, upper
4-023-068-00	(C) Cushion, lower
4-023-091-00	(D) Carton
4-495-699-11	(B) Manual, instruction

Note: The components identified by shading and (A) mark are critical for safety. Replace only with part number specified.

Note: The components identified by shading and (A) mark are critical for safety. Replace only with part number specified.